

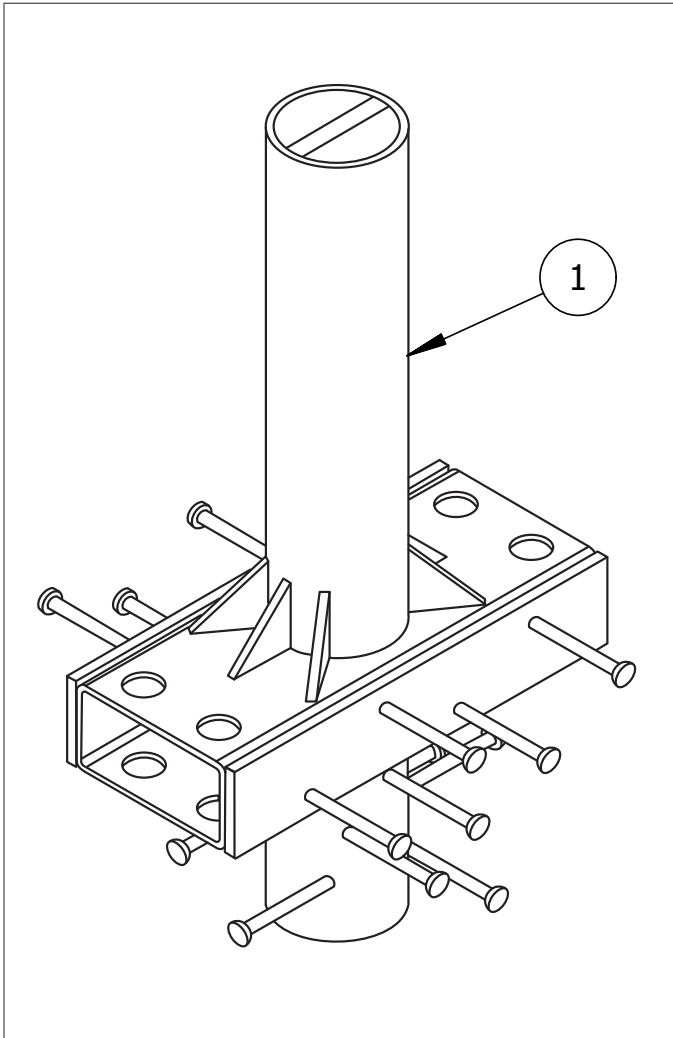



# R-1009-12 Crash-Rated Bollard Installation

**Embedded**

*Bollards shown in the diagrams may not be the same model as the bollards shipped in this order. This does not affect the integrity of the installation.*



-  To protect the finish, keep bollards in original packaging until exact moment of installation.
-  Handle with care to avoid scratching or damaging bollard surfaces as abrasions will lead to rust.
-  Consider local soil conditions before proceeding with bollard installation.

## Parts List

#	PART	QTY
1	Crash-Rated Bollard	1

## Installation Equipment

Dirt Tamper
Level
Metal Construction Pipe
Chalk/Marker
Measuring Tape
Shovel

## Before Installation

**STEP 1:** Study the site plans and mark the intended location of each bollard on the plan.

**STEP 2:** Always check for hazards such as water pipes, gas lines, and underground wiring before digging. *Note: You may need a permit to dig to certain depths or in certain locations.*

# R-1009-12 Crash-Rated Bollard Installation

Embedded

STEP 3 (Side View)

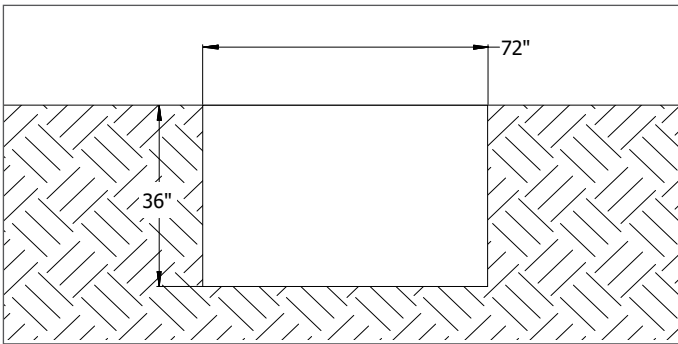

STEP 3 (Top View)

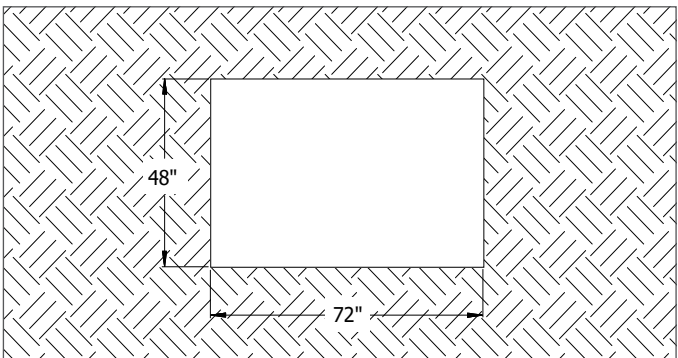

STEP 5

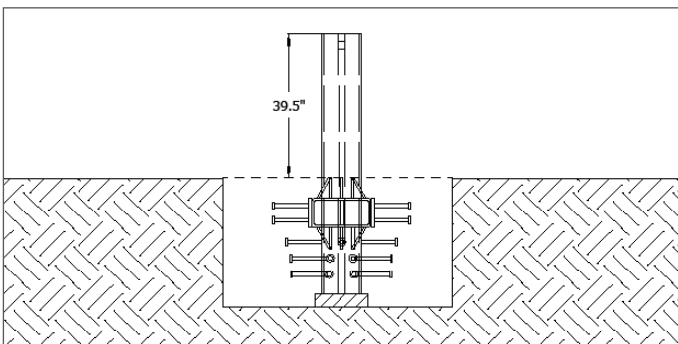

STEP 8

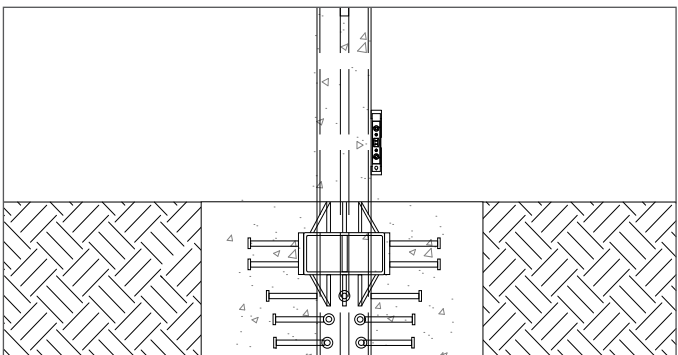

**STEP 3:** Plan the layout and dig a rectangular hole with a width of 72", length of 48", and depth of 36".

**STEP 4:** Set a brace (concrete block or chair) at the bottom of the site. This will elevate the bollard off the subgrade. The bollard should be lifted up enough that the top of the bollard's gusset is flush with the surface grade. The bollard height above grade should be 39.5".

**STEP 5:** Lower the bollard into the site and onto the brace. *Note: Crash-rated bollards are heavy—to prevent accidents and injuries, ensure the proper resources are available to set into place.*

## Pour the Concrete

**STEP 6:** Only use concrete with a minimum 4000 PSI. Mix the concrete. Check that the proper ratio of water and concrete mix is used—the concrete should have a similar texture to moldable clay.

**STEP 7:** Fill the site to the top with concrete until it is level with the surface grade.

## Set the Bollard

**STEP 8:** Hold a level against the side of the bollard and ensure that it is plumb. *Note: Once the concrete has cured, there will be no way to make any adjustments.*

**STEP 9:** Patch the surface around the bollard to make it smooth with the existing surface.

## Clean the Bollard

**STEP 10:** Use a cloth to clean the bollard before the concrete cures.

**STEP 11:** Be sure to allow enough time for concrete to cure before beginning construction projects on new concrete surfaces. *Note: Moisture in the environment and cool temperatures can significantly slow the process.*

**STEP 12:** Landscaping material or concrete can be applied around the bollard base to achieve the desired final grade. *Note: Decorative bollard covers can be installed over crash-rated bollards. Please ensure that the cover is large enough to accommodate the crash-rated bollard. To install, please refer to the cover's installation guide.*